



Redefining Emergency Egress Lighting

Wireless Testing & Reporting Solutions

LynxEM[™]



Lynxus Technologies links the world with advanced design and intelligent development. Our products are created to be industry-leading examples of how to best control lighting.

LynxEM is our complete emergency system providing wireless communication between Emergency Battery Backups, Emergency Exits and other Emergency Lighting- ALL IN ONE PLACE.

Our system is designed to enable maintenance personnel to easily test and maintain the emergency lighting system without the need to walk through the building to manually verify individual performance or disrupt the power.

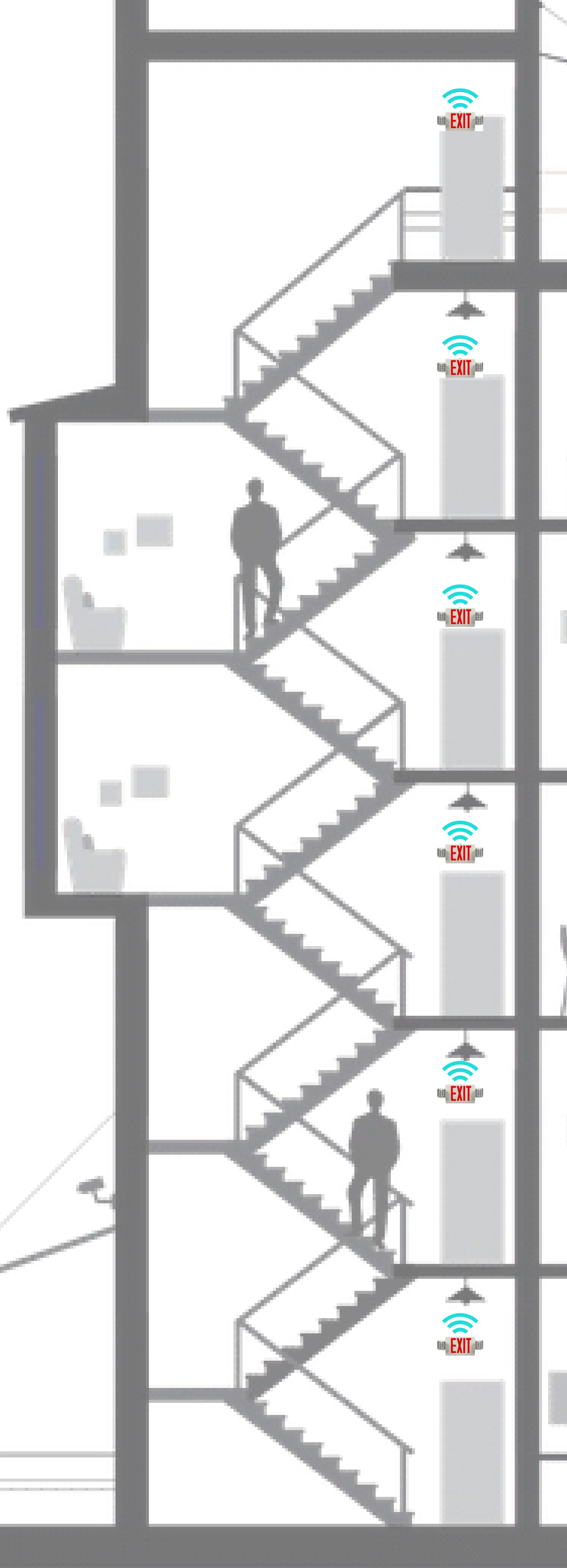
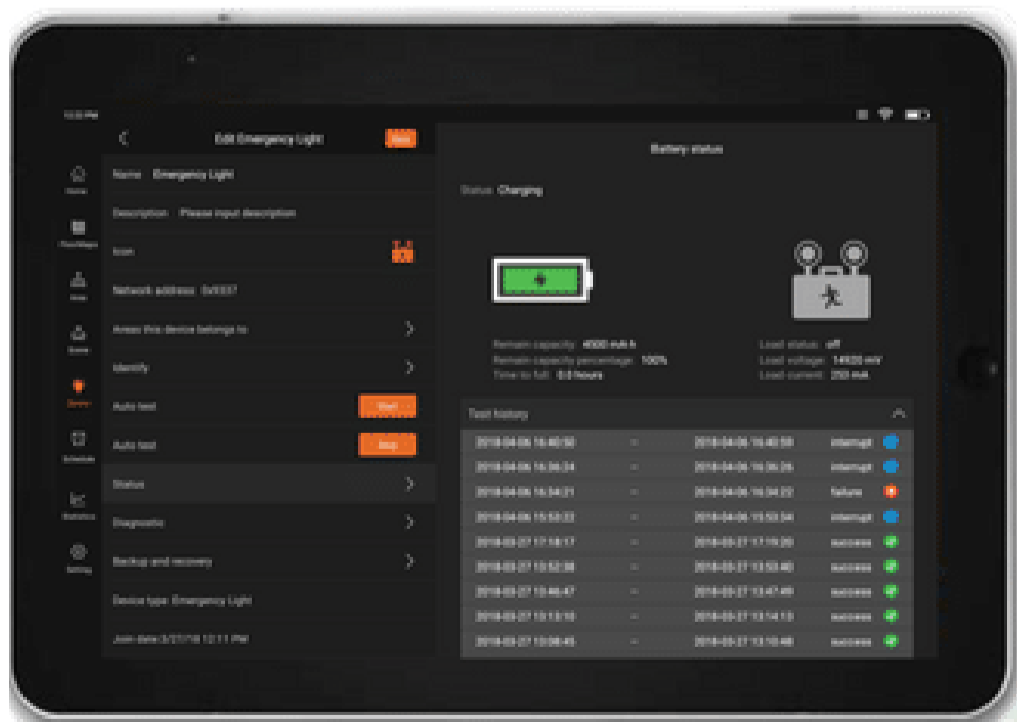



Downloadable App

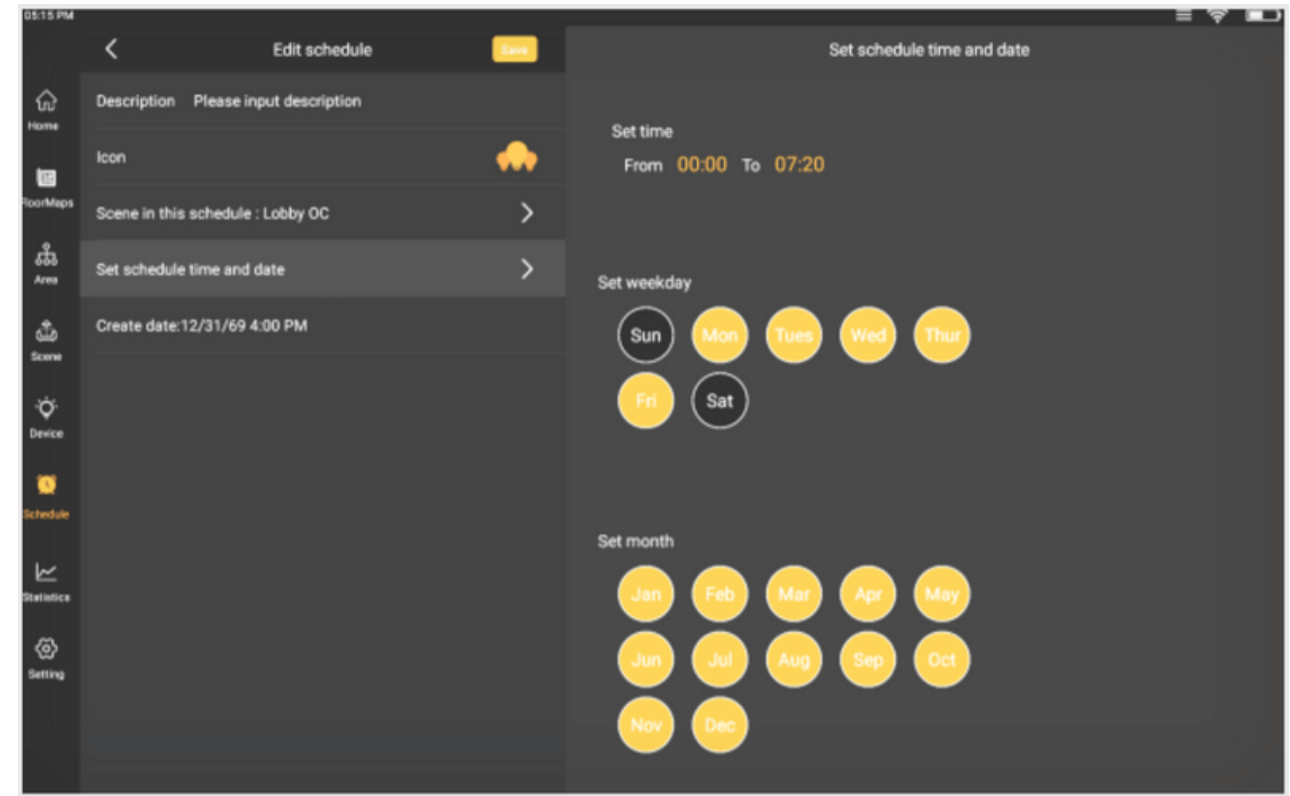

Automatically initiate status reports at programmed intervals for code compliance

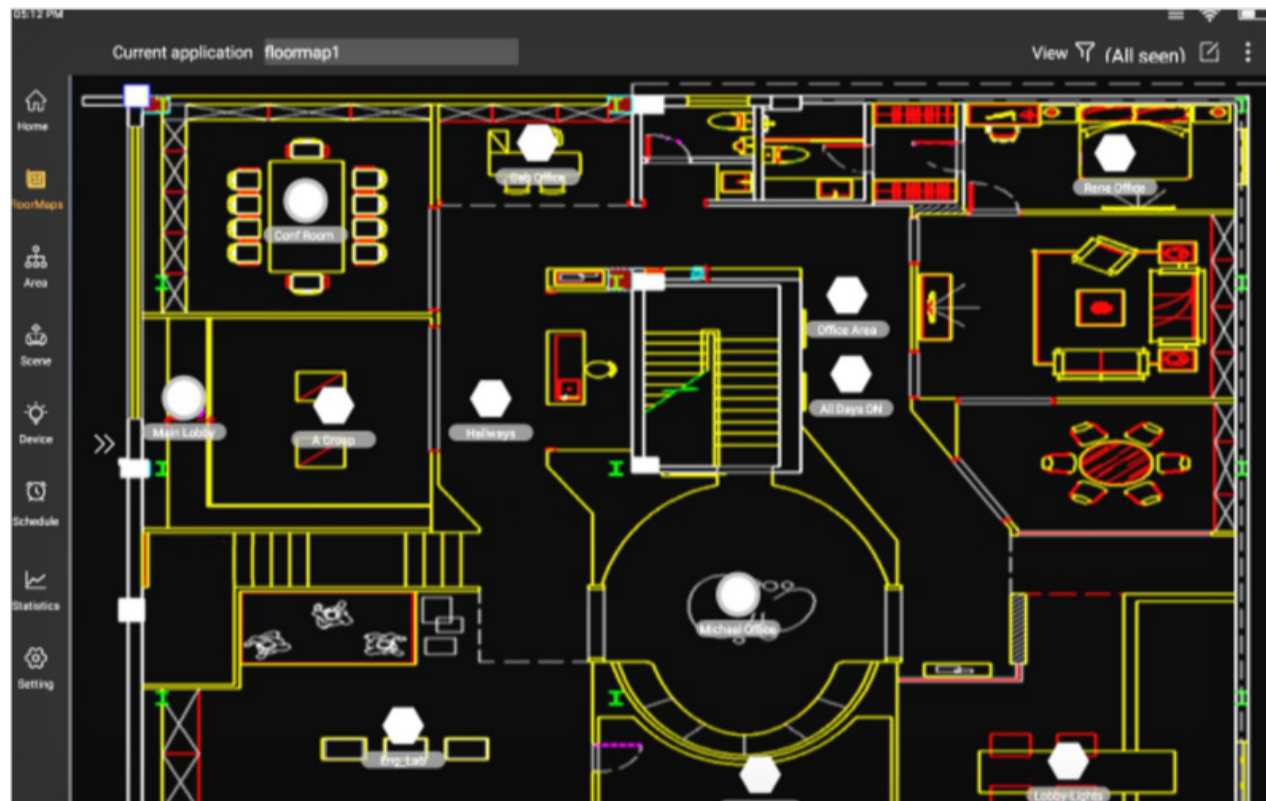

Our easy customization features helps you stay on top of all your system components

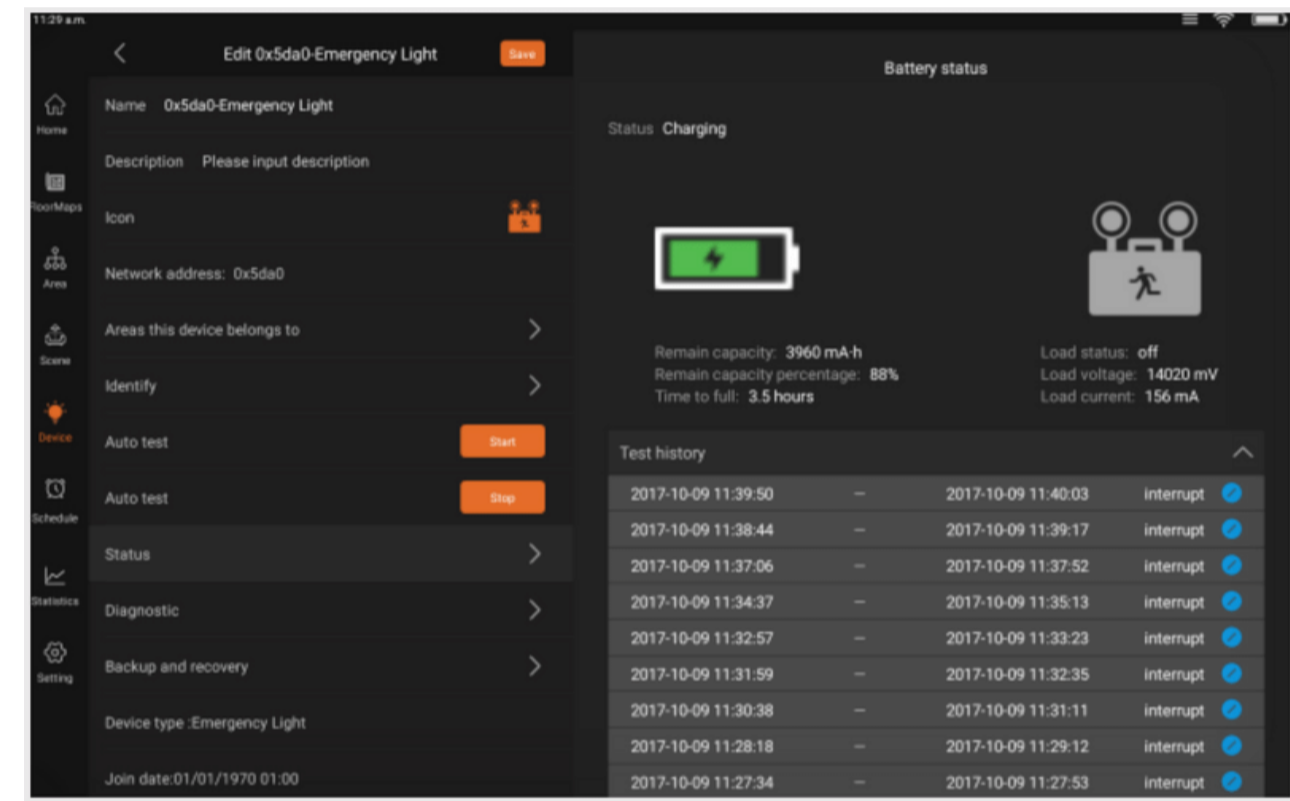

A recommended system for real-time monitoring & reporting

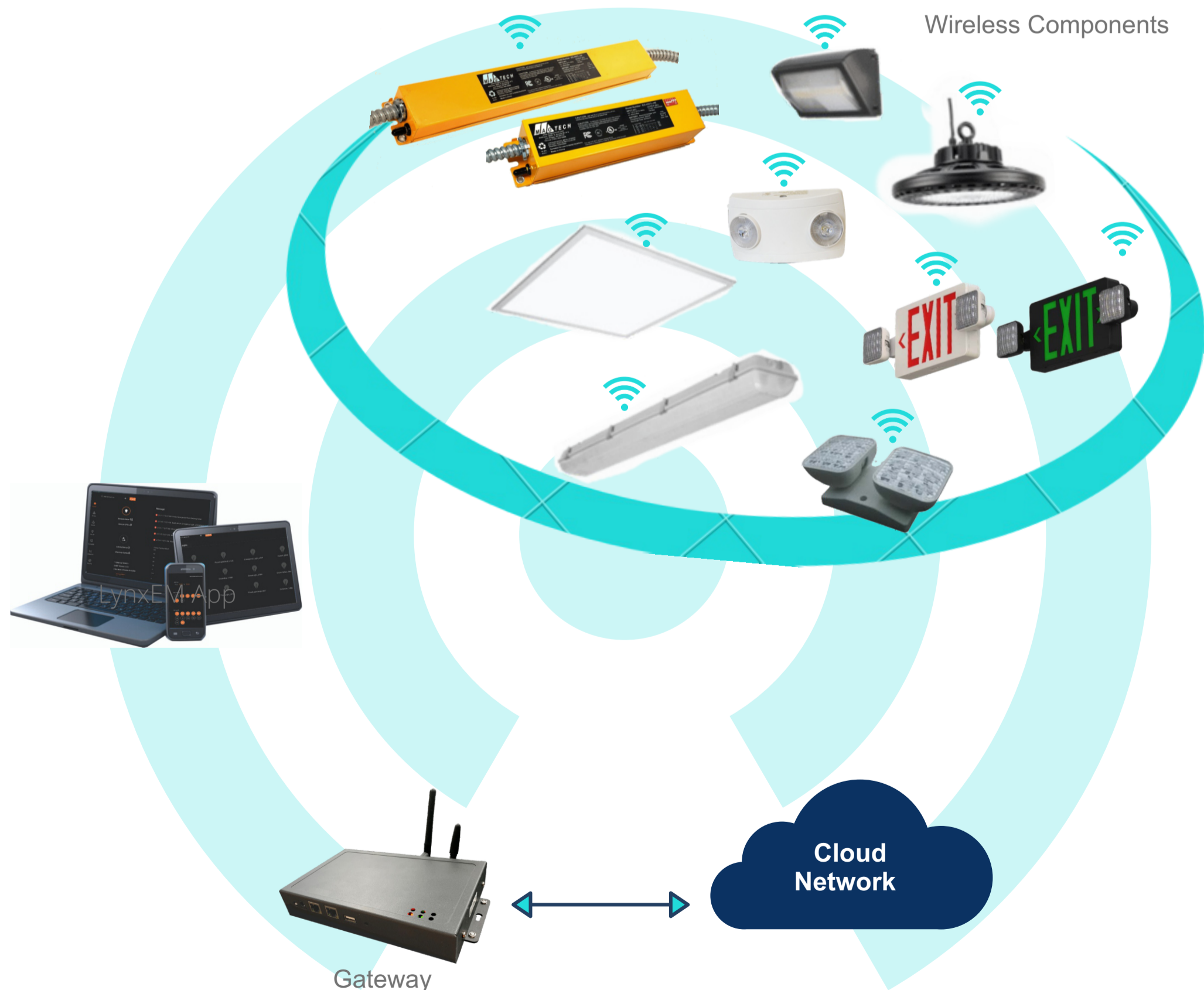

Wireless Emergency Monitoring Cloud-Based System

"LynxEM takes the guess work (*and leg work*) out of emergency testing with wireless emergency battery backups and adapters."

Enjoy Benefits like:

- ✓ Downloadable Reports
- ✓ Cost Savings
- ✓ Reliability
- ✓ Simplicity
- ✓ Flexibility



Are you ready for an inspection?

This system focuses on the ever-expanding and code compliant emergency lighting arena so you'll be safe & prepared for any situation.

With a varied line of wireless products, LynxEM can accommodate any size commercial area and delivers proven, straight-forward results.

These wirelessly connected units all respond, coordinate and report to the LynxusEM app to easily conduct necessary maintenance or testing.



EMERGENCY BATTERY BACKUP - LED DRIVERS

iES LMx

PRODUCT SPECIFICATIONS

- Automatic Self-Test technology
- Monthly and Annual testing
- Microprocessor design for CEC compliance
- Auto adjusting Class 2 output
- Maintenance free Nickel Metal Hydride battery
- USGBS/Green Building Council Certified CEC Title 20
- Constant Current for variable illumination
- Suitable for damp location applications
- Programmable output with great flexibilities



7W Maximum Output Power

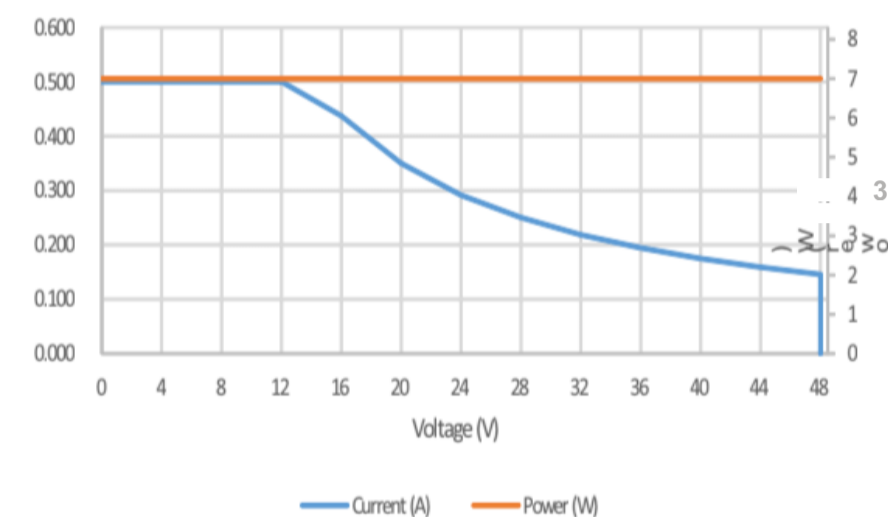

Model No.	Emergency Power	Output Range Vdc	Factory Default Output mA	Max. Output W	SW1	SW2	SW3	SW4
iES-H007L-LMx	7.0W	36	195	7	off	off	on	off
		48	145		off	off	on	on
		36	280		off	off	on	off
iES-H010L-LMx	10 W	48	210	10	off	off	off	on

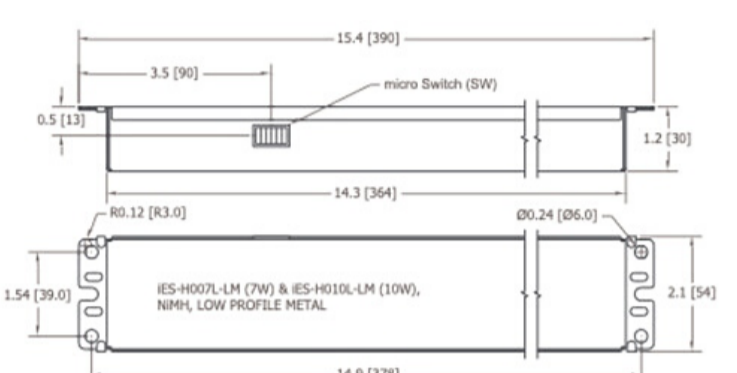

iES HMx

PRODUCT SPECIFICATIONS

- Automatic Self-Test technology
- Monthly and Annual testing
- Microprocessor design for CEC compliance
- Auto adjusting Class 2 output
- Maintenance free Nickel Metal Hydride battery
- USGBS/Green Building Council Certified CEC Title 20
- Constant Current for variable illumination
- Suitable for damp location applications
- Programmable output with great flexibilities



7W Maximum Output Power

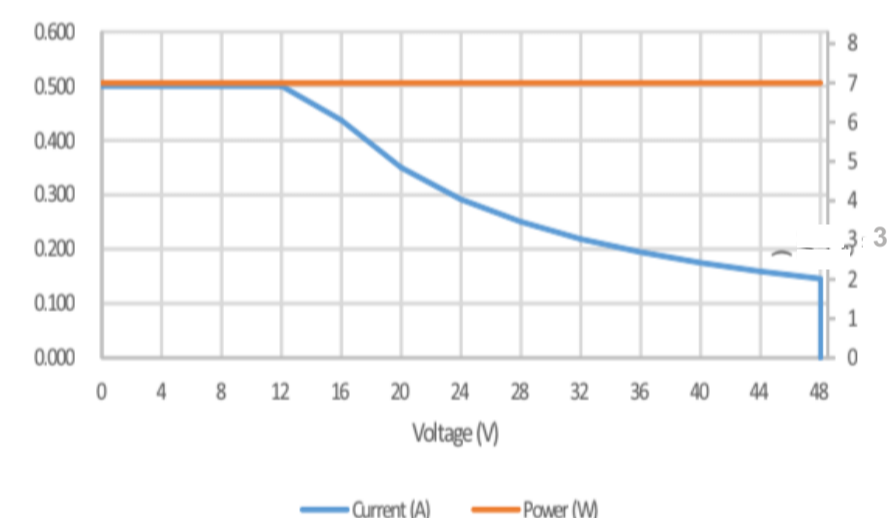

Model No.	Emergency Power	Output Range Vdc	Factory Default Output mA	Max. Output W	SW1	SW2	SW3	SW4
iES-H007L-HMx	7.0W	16	440	7	on	off	off	off
		24	290		off	on	off	off
iES-H010L-HMx	10.0 W	16	625	10	off	on	off	off
		24	425		off	on	off	off
iES-H021L-HMx	21.0 W	24	875	21	on	off	off	off
		36	580		off	on	off	off
		42	500		off	off	on	off
		48	435		off	off	on	

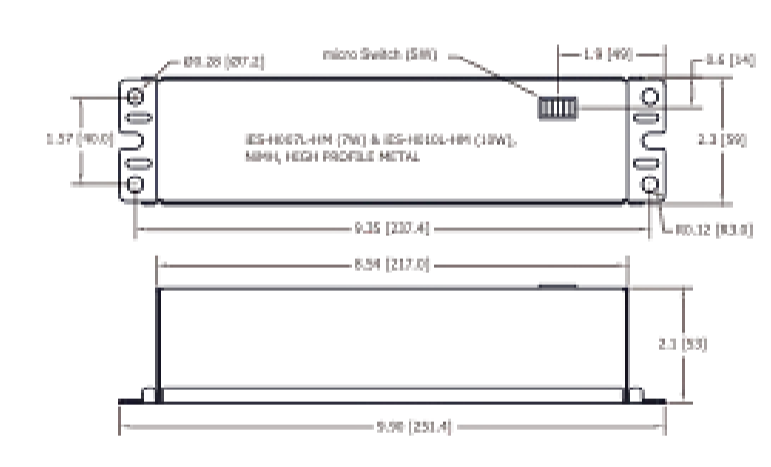

iES NPx

PRODUCT SPECIFICATIONS

- Automatic Self-Test technology
- Monthly and Annual testing
- Microprocessor design for CEC compliance
- Auto adjusting Class 2 output
- Maintenance free Nickel Metal Hydride battery
- USGBS/Green Building Council Certified CEC Title 20
- Constant Current for variable illumination



Model No.	Emergency Power	Output Range Vdc	Factory Default Output mA	Max. Output W	SW1	SW2	SW3	SW4
iES-H007L-NPx	7.0W	16	440	7	on	off	off	off
		24	290		off	on	off	off
		36	195		off	off	on	off
		48	145		off	on	off	on
iES-H010L-NPx	10.5 W	16	625	10.5	on	off	off	off
		24	425		off	on	off	off
		36	280		off	on	on	off
		48	210		off	off	off	on
iES-H021L-NPx	21.0 W	24	875	21	on	off	off	off
		36	580		off	on	off	off
		42	500		off	off	on	off
		48	435		off	off	off	on

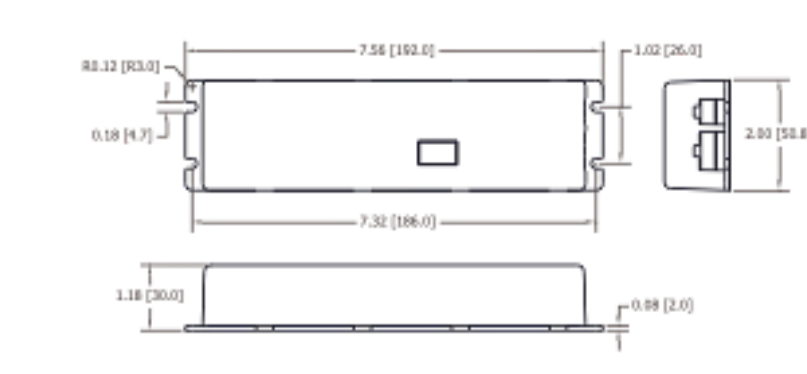

EXIT SIGN COMBO

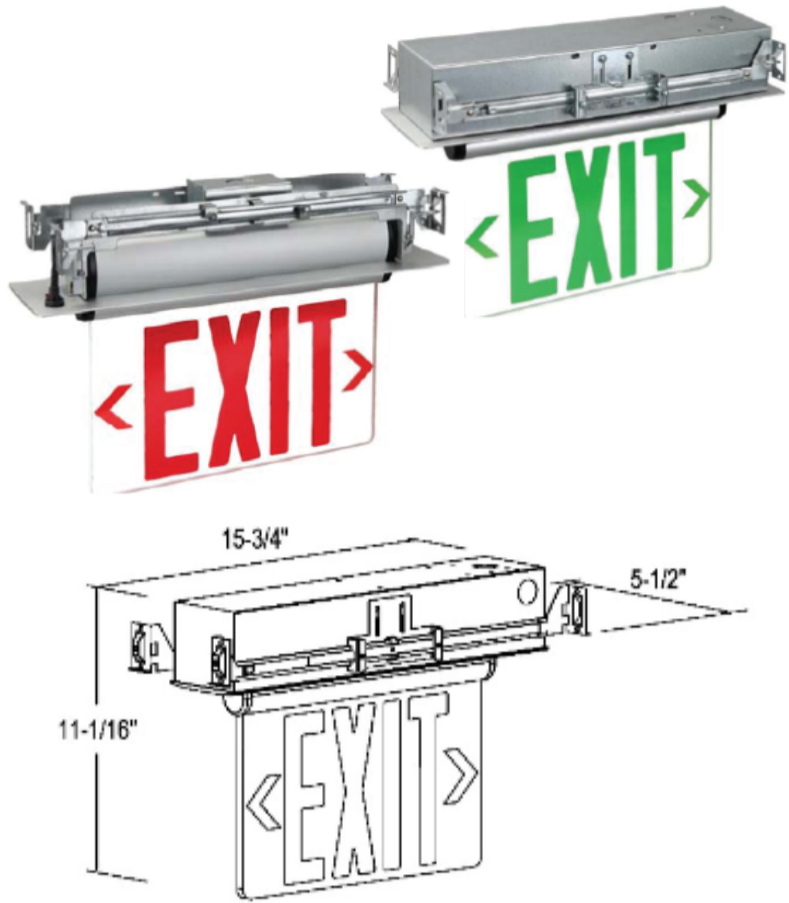

BRSEL SERIES

PRODUCT SPECIFICATIONS

- Compact and decorative design.
- Aluminum housing with high grade acrylic panel.
- Suitable for damp location.
- LynxEM™ wireless testing and reporting system available.
- Suitable for use in 10°C – 40°C ambient temperature.
- Suitable for damp location.
- UL listed and exceed all requirement in NFPA 70.
- NFPA 101 life safety.

Product Series	Series	Number of face	Letter	Background	Function	Housing colour	Input Voltage	Panel
RSEL: Recessed box type	800: Battery backup	S: Single Face	R: Red	C: Clear	Blank: Standard circuit	AL: Aluminum	1: 120/277V	Blank: Standard type
BRSEL: Hanger bar type	800: Battery backup 800: Battery backup	GX: Green	BK: Black	M: Mirror W: White	CT: Self-diagnostics ZD: Wireless Reporting LynxEM™ Control	WH: White	3: 220V	U: Including single and double face panel for universal

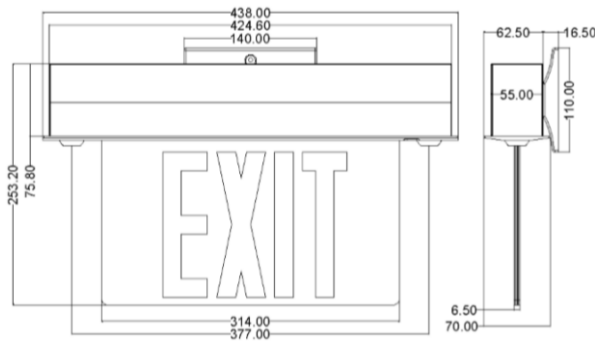

SCCEL-800

PRODUCT SPECIFICATIONS

- Compact and decorative design.
- Aluminum housing with high grade acrylic panel.
- Suitable for damp location.
- LynxEM™ wireless testing and reporting system available.
- Suitable for use in 10°C – 40°C ambient temperature.
- Suitable for damp location.
- UL listed and exceed all requirement in NFPA 70.
- NFPA 101 life safety.

Product Series	Face	Letter Color	Trim Plate Finish	Test Facility	Battery Capacity	Remote Capability
SCCEL-800	S: Single Face	R: Red	AL: Aluminum WH: White	CT: Self-diagnostic	Blank: 3.6V 1800mAh 250Lm output	RC 3.6V Max. 3W remote capacity
	D: Double Face	G: Green	BK: Black	ZD: Wireless Reporting LynxEM™ Control	HO: 3.6V 2500mAh 400Lm output	

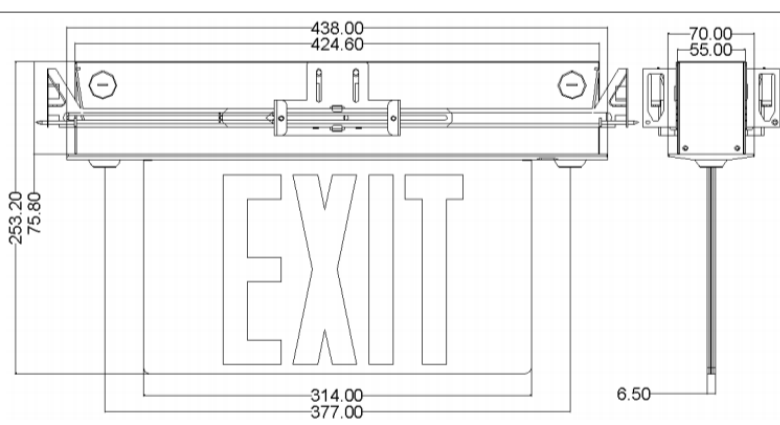

RCEL-800

PRODUCT SPECIFICATIONS

- Recessed ceiling and recessed wall mount.
- High temperature long life Ni-MH battery.
- Acrylic panel changeable design.
- Suitable for damp location.
- Self-testing/self-diagnostic function available.
- 30 degree beam angle.
- Full angle adjustable lamp head.
- Extrusion aluminum alloy trim plate.
- 6" height letter.
- Slim type design.
- Remote capability design with additional battery.

Product Series	Face	Letter Color	Trim Plate Finish	Test Facility	Battery Capacity	Remote Capability
RCEL-800	S: Single Face	R: Red	AL: Aluminum WH: White	CT: Self-diagnostic	Blank: 3.6V 1800mAh 250Lm output	RC 3.6V Max. 3W remote capacity
	D: Double Face	G: Green	BK: Black	ZD: Wireless Reporting LynxEM™ Control	HO: 3.6V 2500mAh 400Lm output	

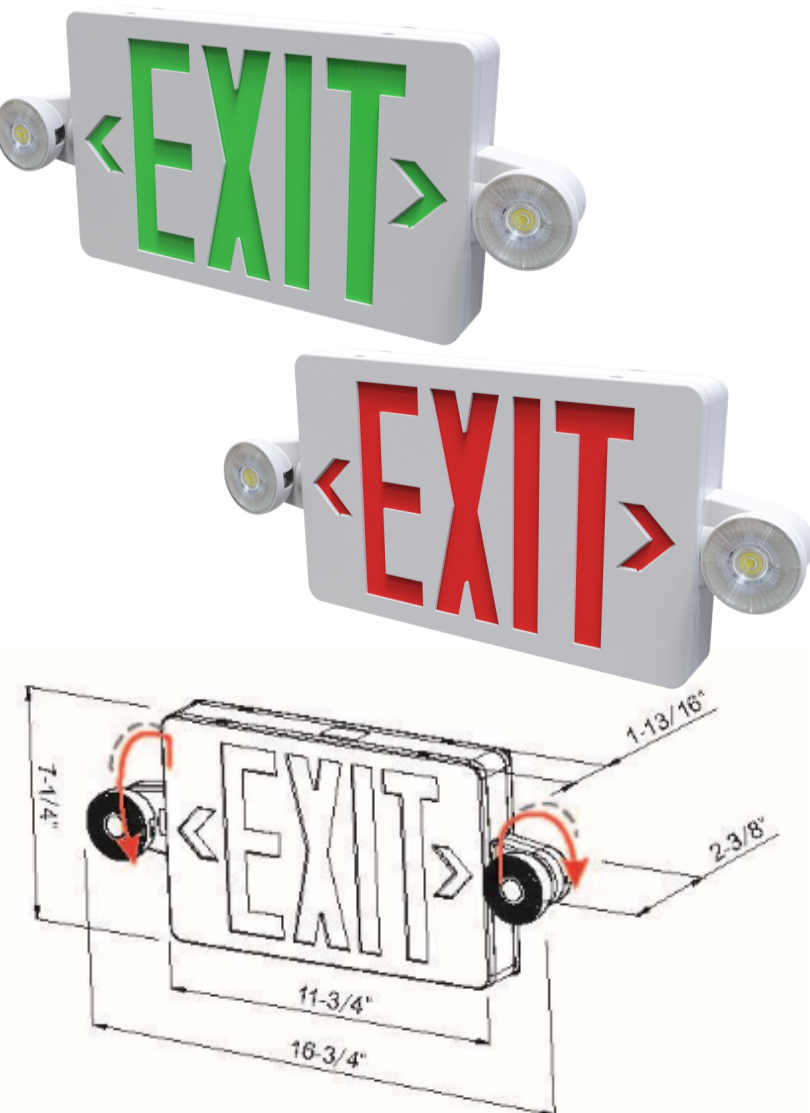

C5 Series

PRODUCT SPECIFICATIONS

- Injection molded thermoplastic housing.
- 6" height letter.
- Fully rotatable lamps head easy snap in housing.
- Suitable for wall mount, ceiling mount.
- Brownout circuit protection for ST/SD.
- High temperature type Ni-cad battery.
- RC option with 3.6V 1.5W remote capability.
- Suitable for damp location.
- UL listed and exceed all requirement in NFPA 70.
- NFPA 101 life safety.

Product Series	Letter Color	Option	Test Facility	Housing Color	Input Voltage
C5 Series	R: Red	Blank: Basic model HO: High lumen output RC: Remote capability	Blank: Manual test	W: White	120/277VAC
	G: Green	ZD: Wireless Reporting LynxEM™ Control	CT: Self-testing / Self-diagnostics	B: Black	

EXIT SIGN COMBO & EXIT SIGN

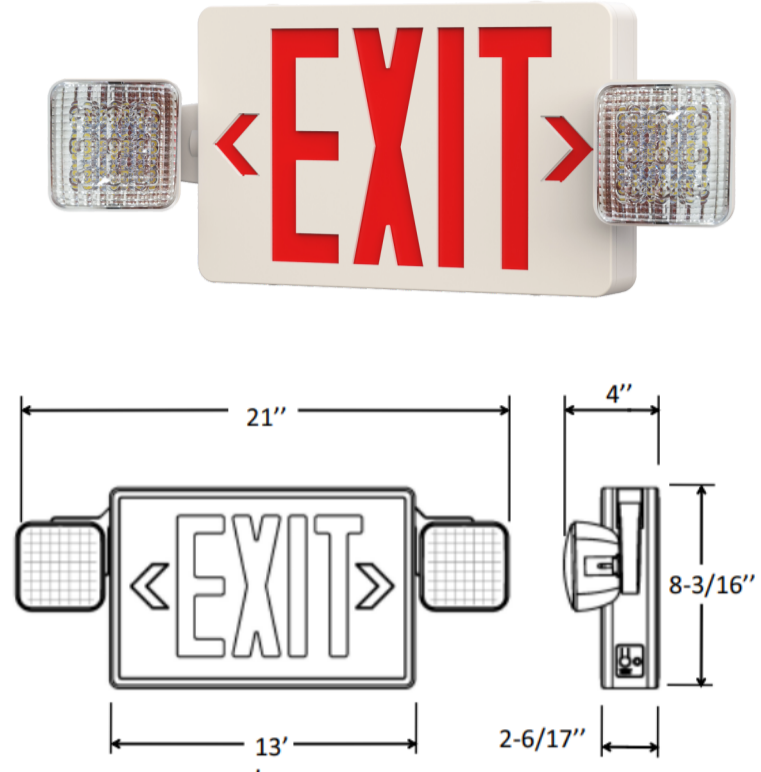

CB – 810

PRODUCT SPECIFICATIONS

- Plastic enclosure with 5VA flame retardant.
- Friendly configuration design for quick installation.
- Fully rotatable lamps head easy snap-in housing.
- Long life LED lamps for uniform diffuser illumination.
- High temp NiCad Battery.
- Suitable for wall mount.
- Battery low voltage protection.
- Test switch & battery charging indicator.

Product Series	Face	Letter color	Lumen Output & Remote Capability	Test Facility	Housing Color	Voltage
CB-810	D: Universal for double face & single face	R: Red	Blank: Standard lumen output, no remote capability. RC: Standard lumen output with remote capability.	Blank: Manual test CT: Self-testing / Self-diagnostics ZD: Wireless Reporting LynxEM™ Control	W: White	120/277VAC
	S: Single face	G: Green	HO: High lumen output, without remote capability. HORC: High lumen output with remote capability.		B: Black	

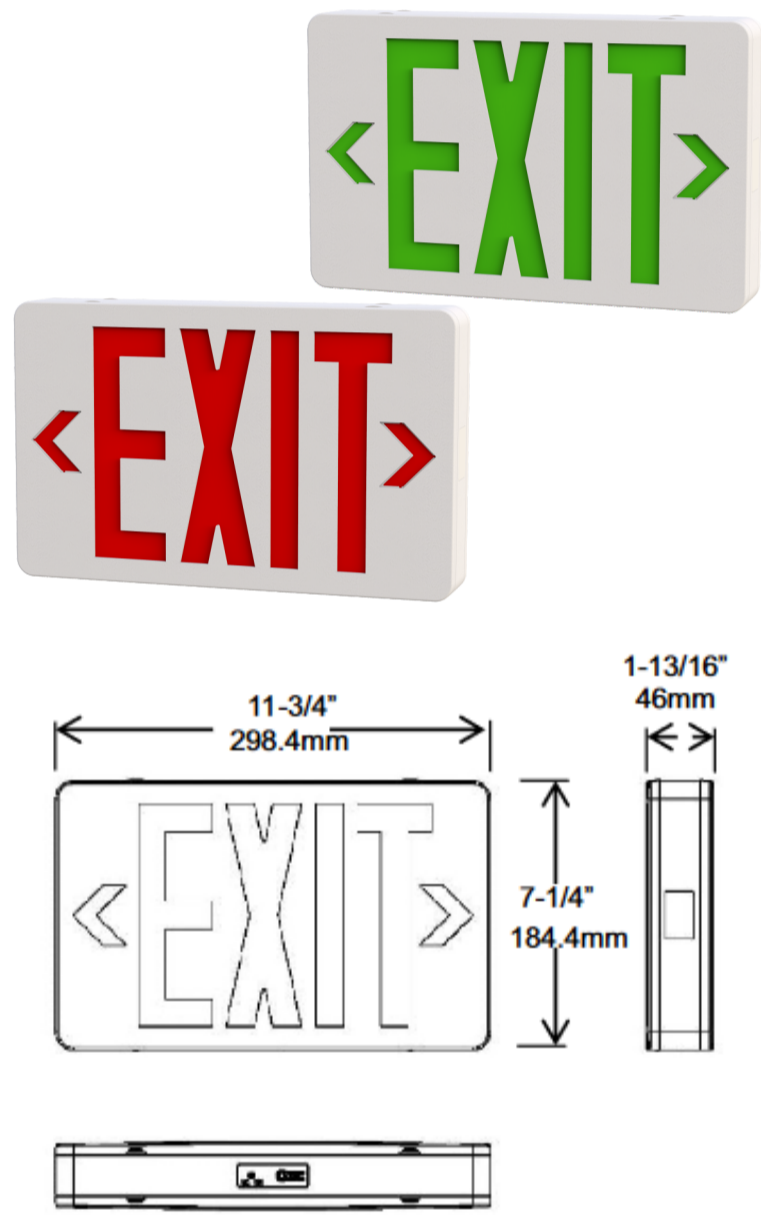

S1 Series

PRODUCT SPECIFICATIONS

- Injection molded thermoplastic housing.
- 6" height letter.
- LynxEM™ wireless testing and reporting system available.
- Fully rotatable lamps head easy snap in housing.
- Suitable for wall mount, ceiling mount.
- Brownout circuit protection for ST/SD.
- High temperature type Ni-cad battery.
- Suitable for damp location.
- UL listed and exceed all requirement in NFPA 70.
- NFPA 101 life safety.

Product Series	Legend	Test Facility	Housing Color	Voltage
S1 Series	R: Red	Blank: Manual test CT: Self-testing / Self-diagnostics	W: White	120/277VAC
	G: Green	ZD: Wireless Reporting LynxEM™ Control	B: Black	

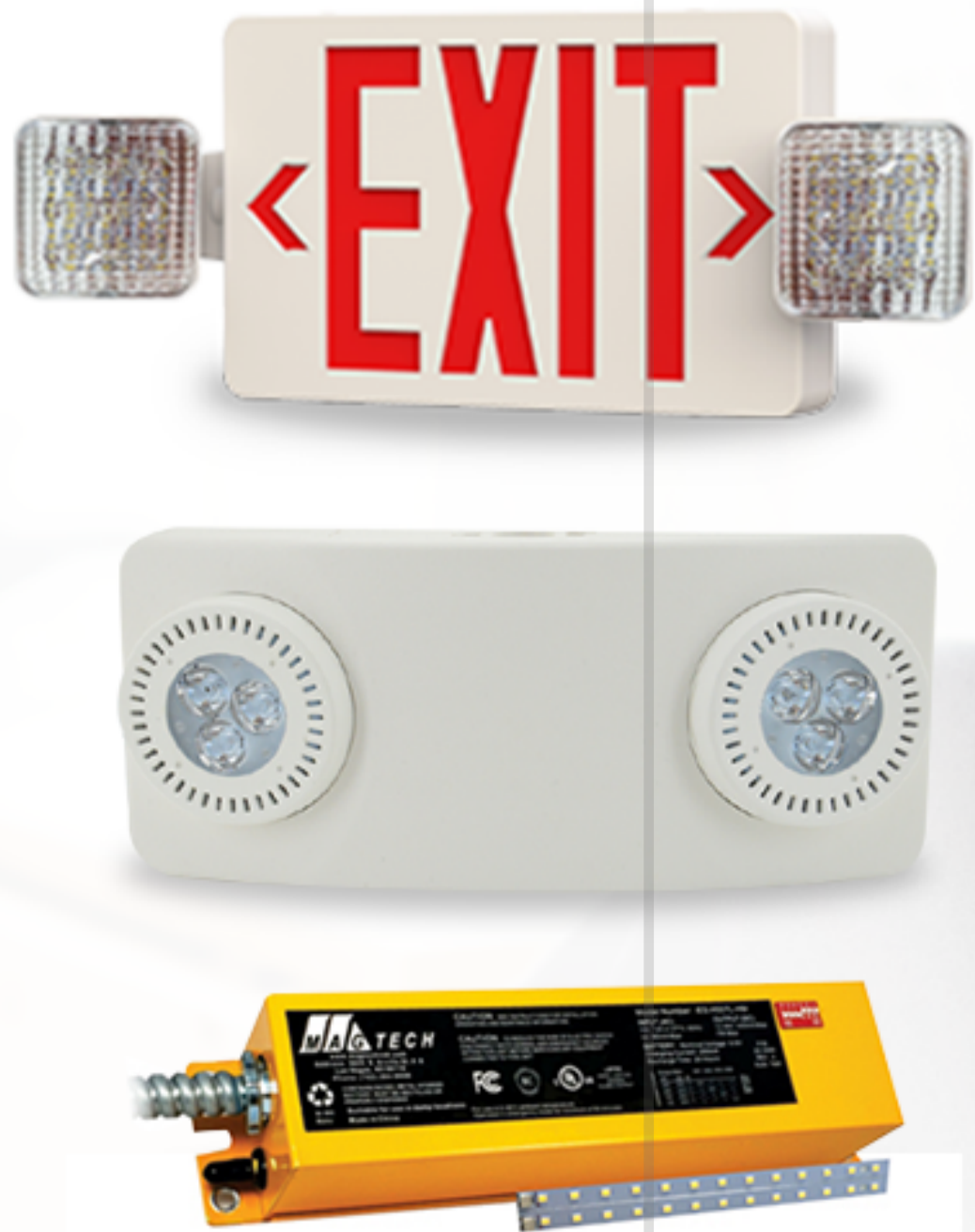

EMERGENCY LIGHTS

EXL – 660L Series

PRODUCT SPECIFICATIONS

- Injection-molded thermoplastic ABS housing.
- Plastic enclosure with 5VA flame retardant.
- Quick connector design for easy installation.
- Two fully adjustable glare-free square shape light heads for emergency light.
- Suitable for wall and ceiling mount.
- Suitable for use in 10°C – 40°C ambient temperature, damp locations.

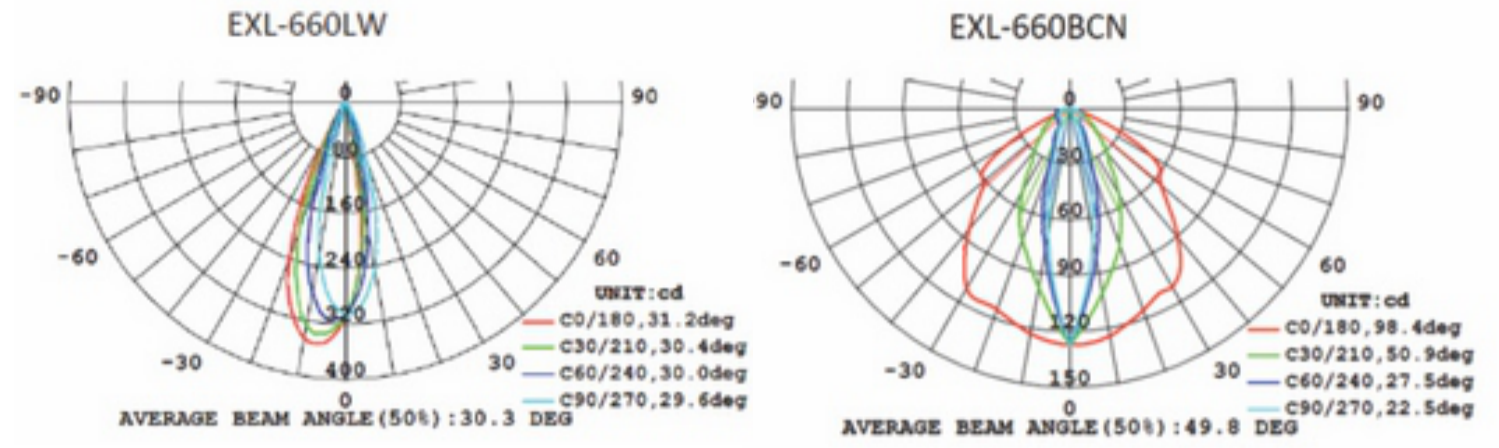

Product Series	Lens	Lumen output & Remote capability	Test Facility	Housing Color	Voltage
EXL-660L	W: General Lens	Blank: Standard lumen output, w/o remote capability. 2RC: Standard lumen output, with 3.6V2.5W remote capability. 4RC: Standard lumen output, with 3.6V2.5W remote capability.	Blank: Manual test CT: Self-testing / Self-diagnostics ZD: Wireless Reporting LynxEM™ Control	W: White	1: 120/277VAC 3: 220-240V
	N: Narrow Lens	HO: High lumen output, w/o remote capability. HO2RC: High lumen output, with 3.6V1.5W remote capability.		B: Black	

EXL – 700 Series

PRODUCT SPECIFICATIONS

- Injection-molded thermoplastic ABS housing.
- Plastic enclosure with 5VA flame retardant.
- Quick connector design for easy installation.
- Two fully adjustable glare-free square shape light heads for emergency light.
- Suitable for wall and ceiling mount.

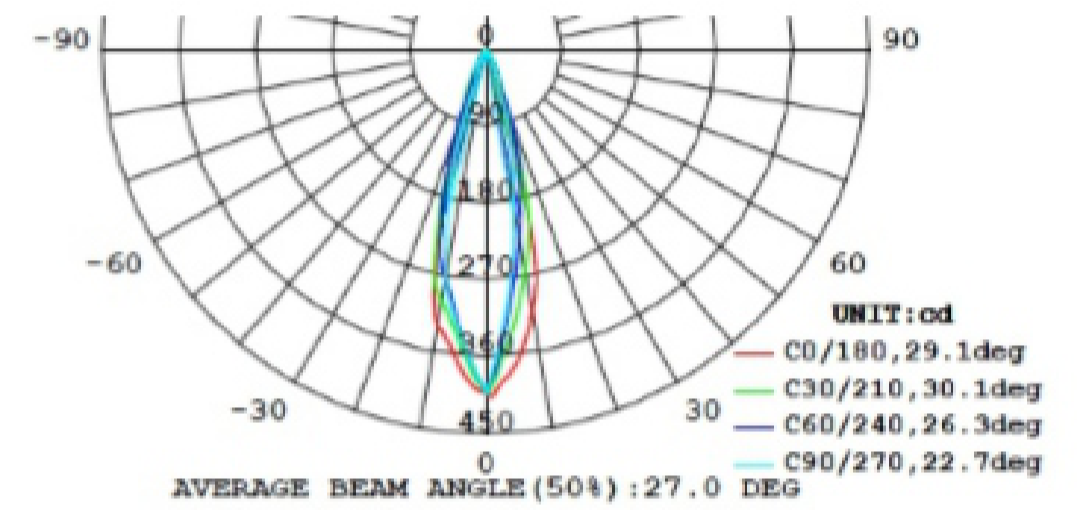

Product Series	Lumen output & Remote capability	Test Facility	Housing Color	Voltage
EXL-700	Blank: Standard lumen output, w/o remote capability. 2RC: Standard lumen output, with 3.6V2.5W remote capability. 4RC: Standard lumen output, with 3.6V2.5W remote capability.	Blank: Manual test CT: Self-testing / Self-diagnostics ZD: Wireless Reporting LynxEM™ Control	W: White	1: 120/277VAC 3: 220-240V
	HO: High lumen output, w/o remote capability. HO2RC: High lumen output, with 3.6V1.5W remote capability.		B: Black	

EXL – 1960 Series

PRODUCT SPECIFICATIONS

- Injection molded thermoplastic ABS housing.
- UL 5VA flame rating.
- High-efficiency for CEC Compliance.
- Long pathway distance.
- Lithium iron phosphate or NIMH battery.
- Remote capability.
- Self-diagnostics/self testing. (optional)

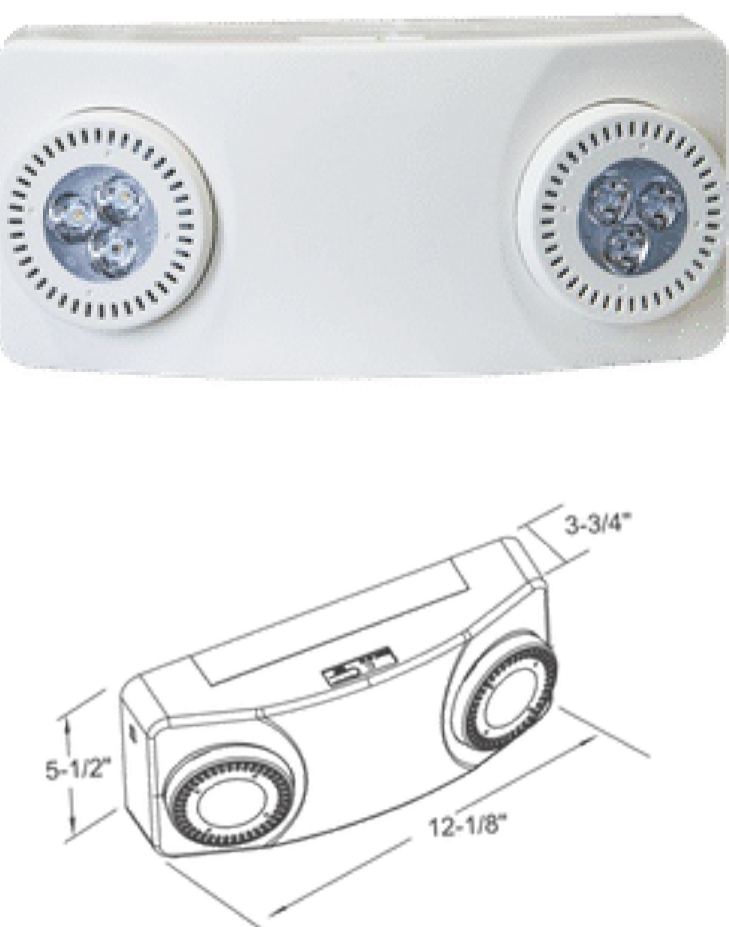
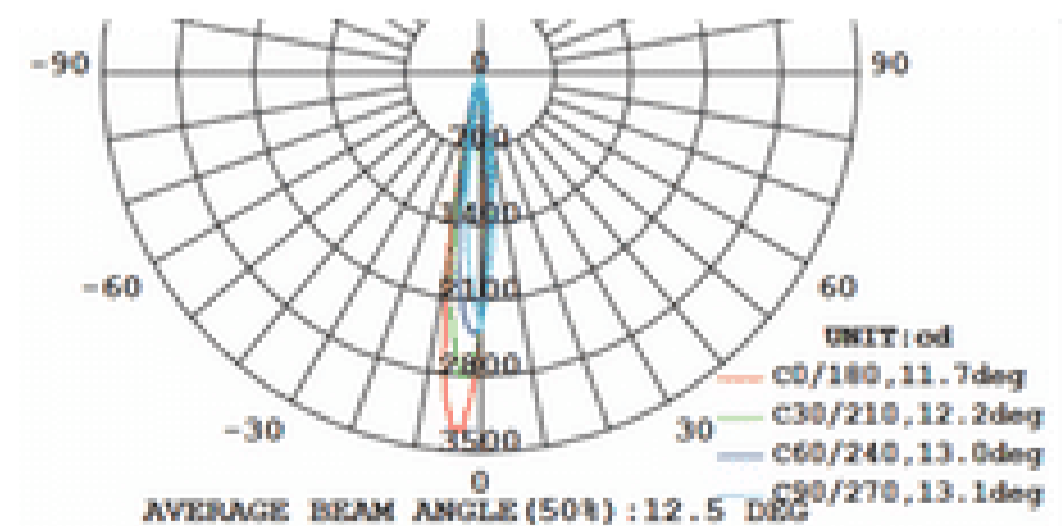

Product Series	Battery	Test Facility	Housing Color
EXL-1960 Standard Version	LFP: LifePO4 battery	Blank: Manual test CT: Self-testing / Self-diagnostics	W: White
EXL-1960HO Premium version high lumen output		ZD: Wireless Reporting LynxEM™ Control	B: Black

OUTDOOR SOLUTIONS

WPL01 Series

PRODUCT SPECIFICATIONS

- Architectural, low profile decorative design.
- Die-cast aluminum housing with e□□ heat sink.
- Enclosure rated IP65 per IEC 60529.
- Suited for outdoor use.
- UV resistant polycarbonate lens.
- Universal pattern knockouts on back plate for junction box.
- 1/2" threaded conduit access on top surface.
- Black, white, dark bronze, silver UV resistant powder paint finish.

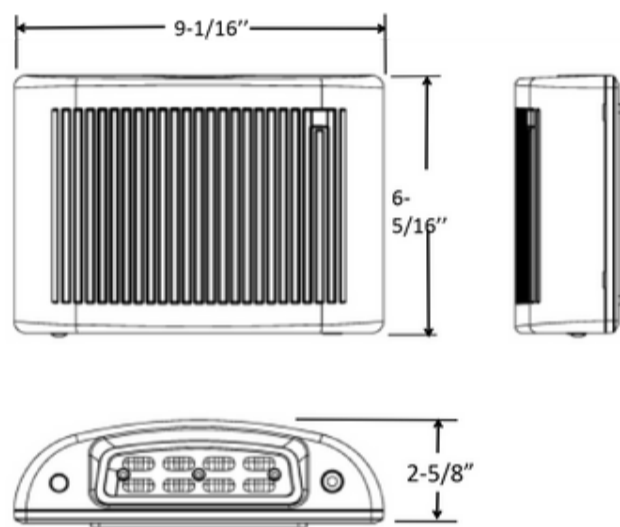

Emergency Mode (ACEM Model)

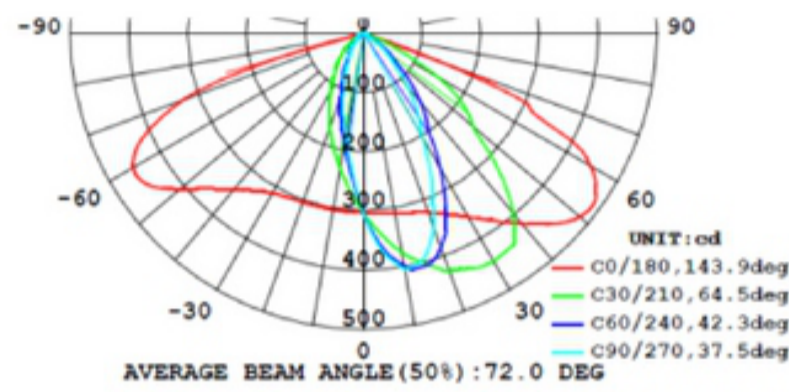

AC Mode

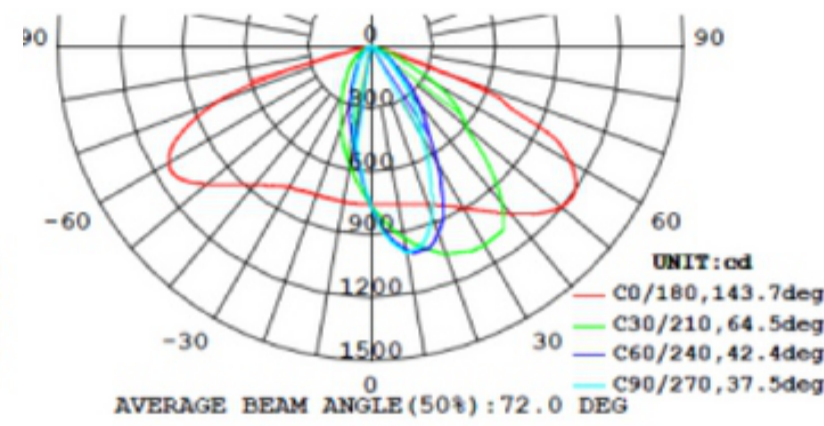

Emergency Mode (ACEM-CL Model)

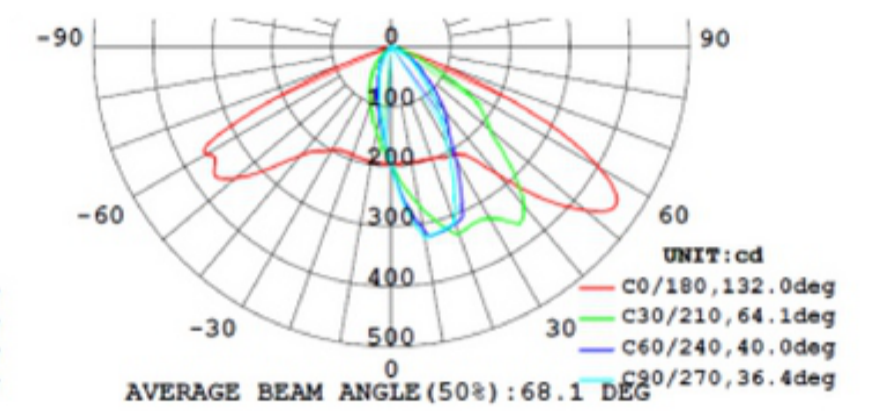

Product Series	LED CCT	Operation	Sensor	Test Facility (for EM item)	Heat Pad (for EM item)	Housing color
WPL01	C: Cold white, 5000k	ACEM: General lighting and emergency	Blank: Photo sensor PIR: Photo sensor and PIR sensor	Blank: Manual test CT: Self-testing / Self-diagnostics ZD: Wireless Reporting LynxEM™ Control	Black: no heat pad	AL: Silver
	N: Natural white, 4000k					BK: Black
	W: Warm white, 3000k	AC: General lighting			B: Black	DB: Dark bronze WH: White

WEDL – 901 Series

PRODUCT SPECIFICATIONS

- Architectural, low profile decorative design.
- Die-cast aluminum housing.
- Polycarbonate lens with mirroring reflector.
- Maintain full lumens output duration battery discharge.
- AC and ACEM model with quick connector.
- Heat pad for wet weather. (optional)
- Suit for cold weather.
- Photo-sensor or wall switch function for AC and ACEM model.

AC Mode

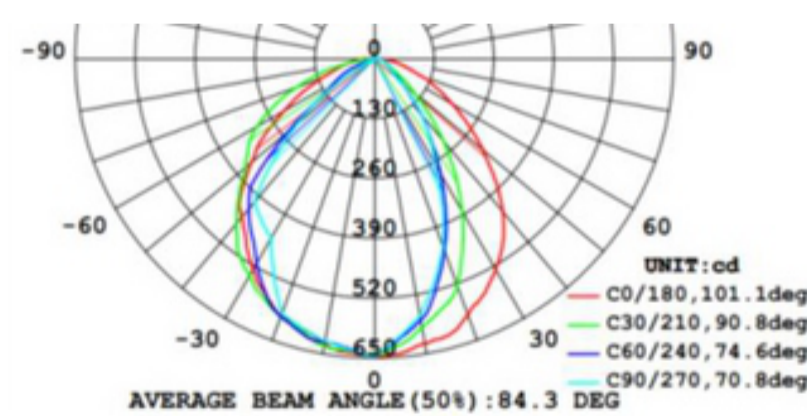

Battery Mode

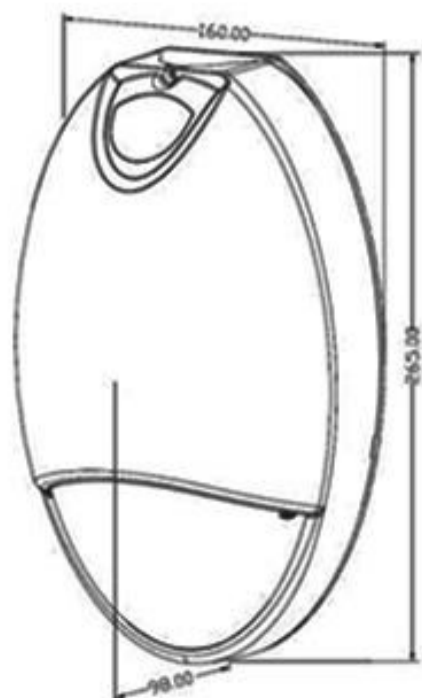
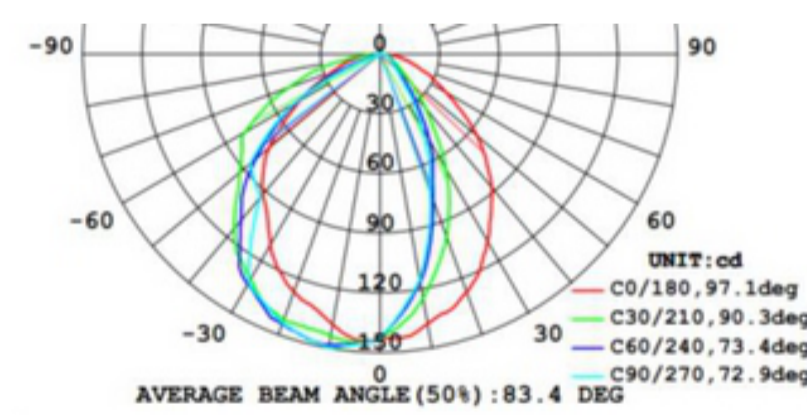

Product Series	Operating Mode	Test Facility	Battery	Recharge Time	Duration
WEDL-901-AC	AC Only	N/A	N/A	N/A	N/A
WEDL-901-ACEM-(CL)	AC and Emergency	Self-testing / Self-diagnostics	Ni-Cd 4.8V 1.8Ah	24H	90 Mins
WEDL-901-EM-(CL)	Emergency	Self-testing / Self-diagnostics	Ni-Cd 4.8V 1.8Ah	24H	90 Mins
WEDL-901-EM-(ZD)	Emergency	Wireless Reporting LynxEM™ Control	Ni-Cd 4.8V 1.8Ah	24H	90 Mins

NEW YORK CERTIFIED SOLUTIONS

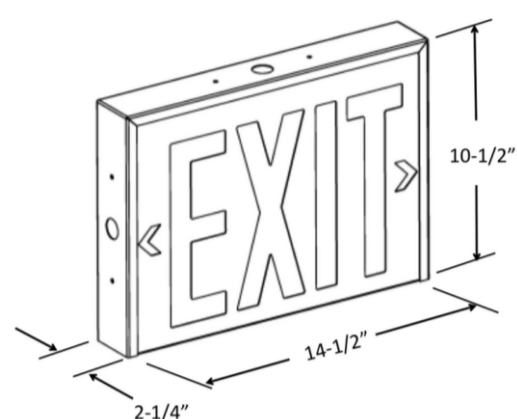

MEX – 800 Series

PRODUCT SPECIFICATIONS

- Heavy duty steel housing with white powder coated finish.
- Single and double face universal design.
- Suitable for damp locations.
- Snap-out knockout and chevron directional arrows.
- Test switch & charge rate indicator.
- Red exit lettering with 8" height and 1" stroke.
- Wall mounting.

Product Series	Operation	Test Facility	Housing color
MEX – 800	800R: Battery backup, red color	ZD: Wireless Reporting LynxEM™ Control	W: White
	810R: AC only, red color		B: Black

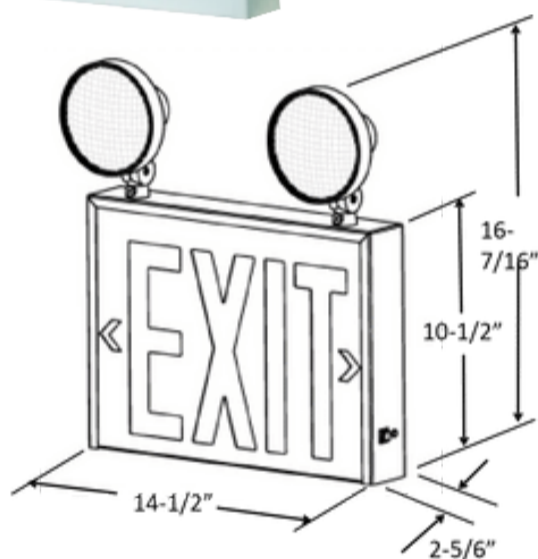

MEX – 800L Series

PRODUCT SPECIFICATIONS

- Heavy duty steel housing with white powder coated finish.
- Single and double face universal design.
- Suitable for damp locations.
- Snap-out knockout and chevron directional arrows.
- Test switch & charge rate indicator.
- Red exit lettering with 8" height and 1" stroke.
- Wall mounting.

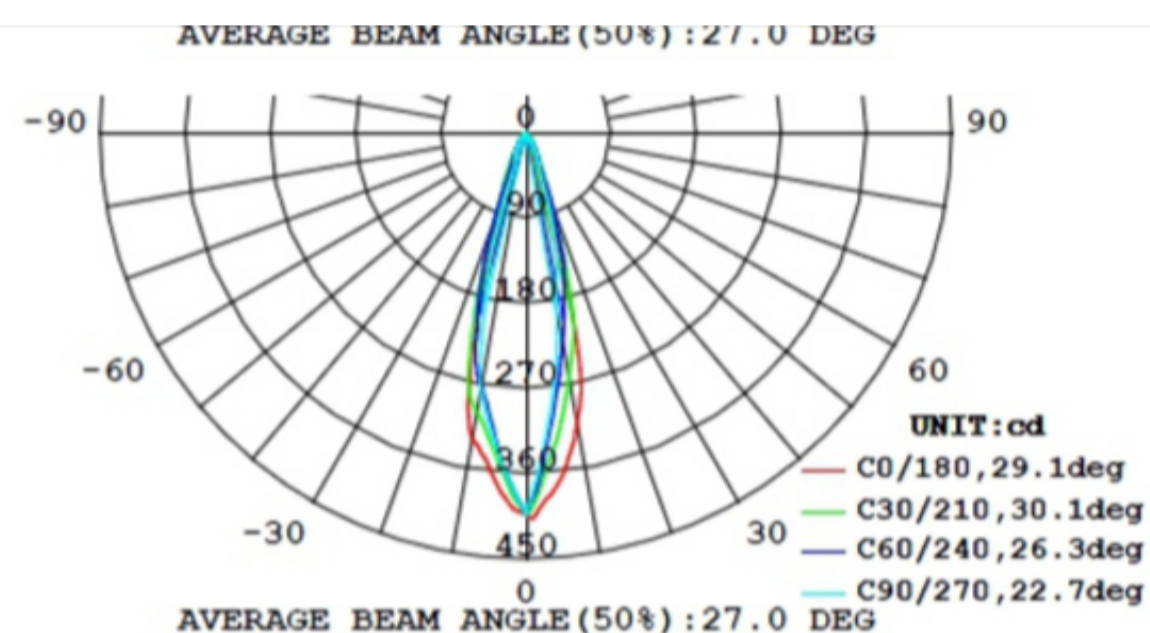

Product Series	Lamp Heads	Test Facility	Housing color
MEX – 800L	2H: 2 Heads	ZD: Wireless Reporting LynxEM™ Control	W: White
	3H: 3 Heads		

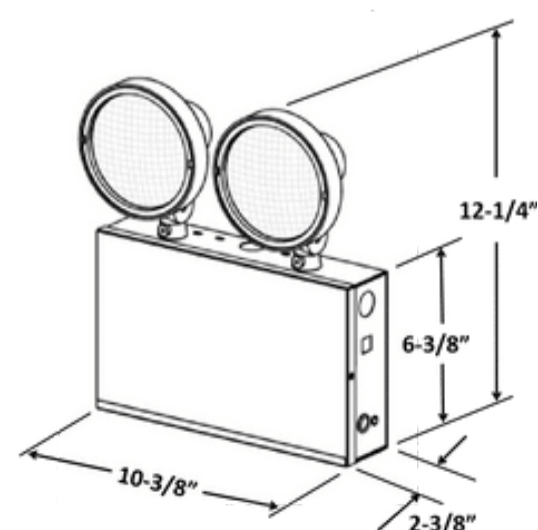

MEXL – 900L Series

PRODUCT SPECIFICATIONS

- Heavy duty steel housing with white powder coated finish.
- Plastic lamp housing with rated 5VA flame retardant.
- Removable knockout hole for wall mounting.
- Two glare-free, adjustable round heads.
- Suitable for wall mount.
- Test switch and AC supply LED indicator.
- Rechargeable Ni-Cad Battery.
- Suitable for damp locations.

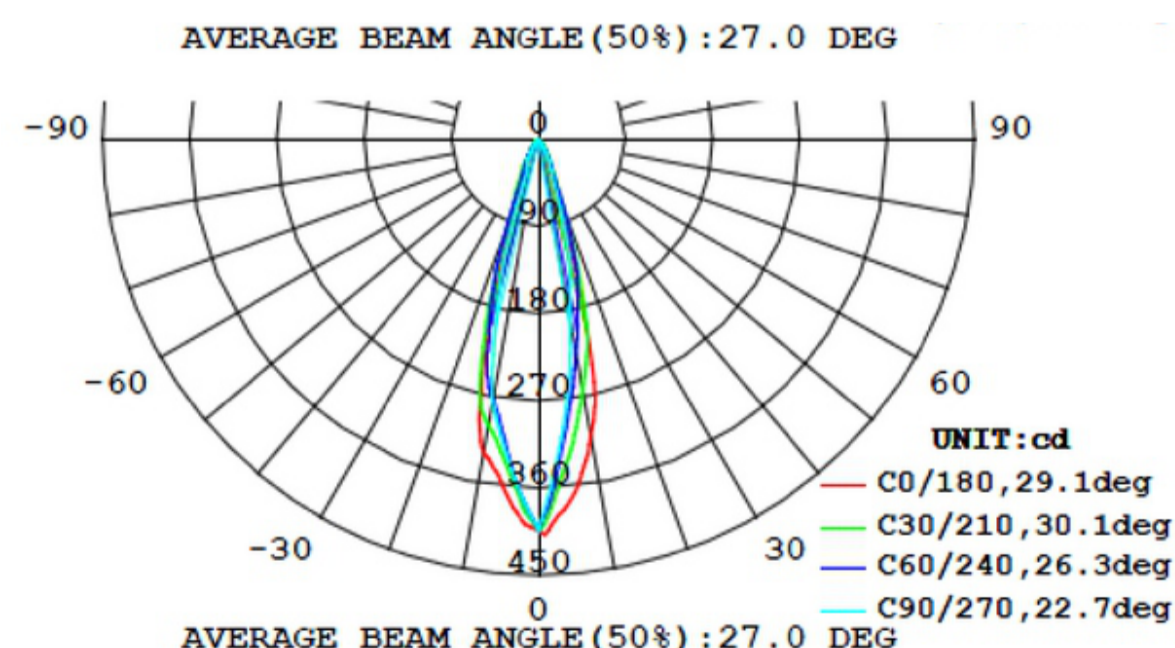

Product Series	Battery	Test Facility	Recharge Time	Emergency duration	Housing color
MEXL – 900L	Ni-cad 3.6V1000mA	Blank: Manual testing ZD: Wireless Reporting LynxEM™ Control	24 Hours	90 Mins	W: White

WET AND COLD LOCATION



WMU – Series

PRODUCT SPECIFICATIONS

- Polycarbonate material and waterproof design.
- LynxEM™ wireless testing and reporting system control.
- High temperature type Ni-cad battery.
- Suitable for wet location.
- Wall mount.
- 24 hours recharge more than 90 mins discharge.
- Normal model expect 660lm output.
- RC model with remote capability expect 380lm output.

Product Series	Options	Housing color
WMU: Waterproof EM	RC: Remote capability option.	WH: White
	Blank: Manual testing, no remote capability.	
	CT: Self-testing / Self-diagnostics	BK: Black
	CL: Cold weather optional.	
	ZD: Wireless Reporting LynxEM™ Control	

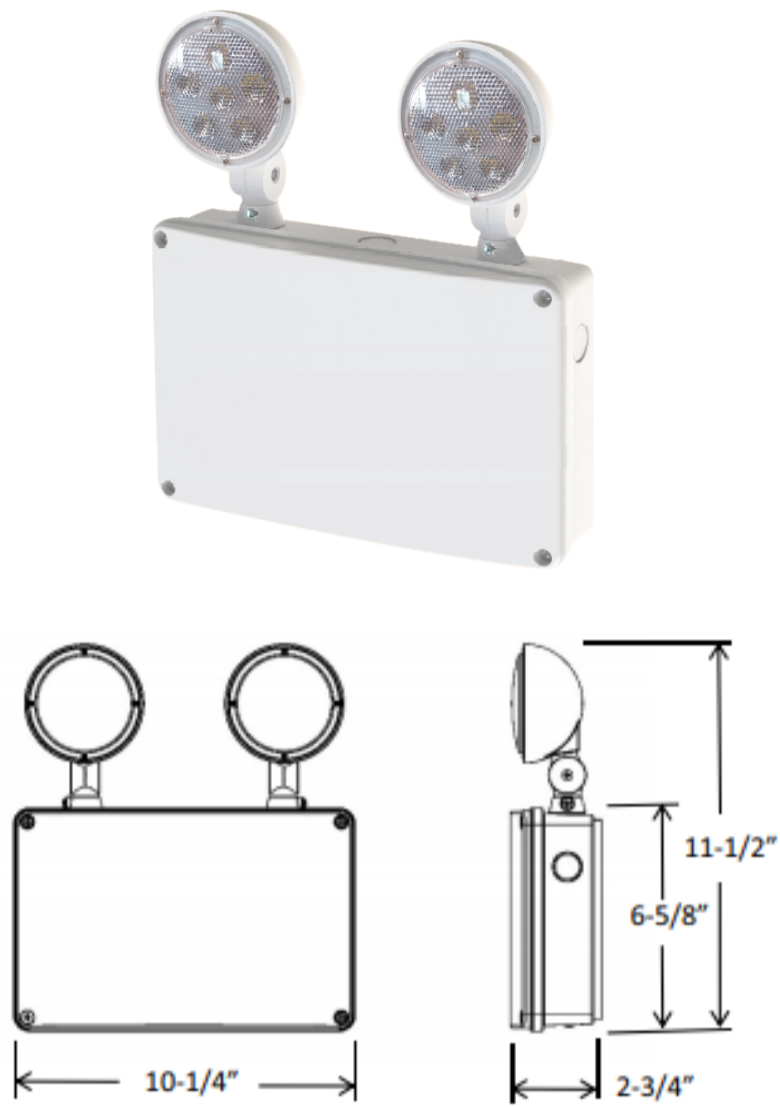

WCU – Series

PRODUCT SPECIFICATIONS

- Polycarbonate material and waterproof design.
- LynxEM™ wireless testing and reporting system control.
- High temperature type Ni-cad battery.
- Suitable for wet location.
- Wall mount.
- 24 hours recharge more than 90 mins discharge.
- Normal model expect 660lm output.
- RC model with remote capability expect 380lm output.

Product Series	Exit sign	Options	Housing color	Option	Input voltage
WMU: Waterproof combo	R: Red color, single face	RC: Remote capability option.	WH: White	U: Extra one more exit panel for single face and double face universal.	1: 120/277V
		Blank: Manual testing, no remote capability.			
	G: Green color, single face	CT: Self-testing / Self-diagnostics	BK: Black		
		CL: Cold weather optional.			
		ZD: Wireless Reporting LynxEM™ Control			

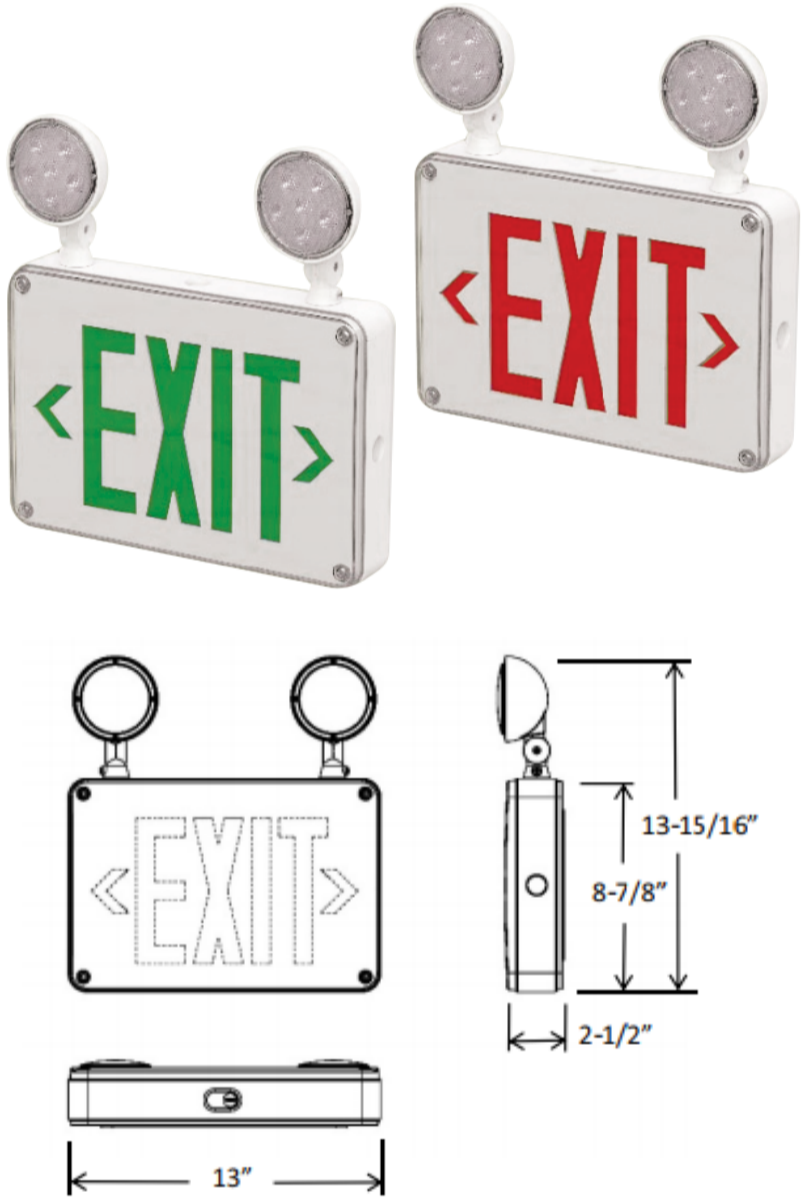

WSU – Series

PRODUCT SPECIFICATIONS

- Polycarbonate material and waterproof design.
- LynxEM™ wireless testing and reporting system control.
- High temperature type Ni-cad battery.
- Suitable for wet location.
- Wall mount.
- 24 hours recharge more than 90 mins discharge.
- DUAL AC input AC/AC circuit available
- Long life red or green LED lamp provide uniform exit sign illumination.
- Normal model expect 660lm output.
- RC model with remote capability expect 380lm output.

Product Series	Exit sign	Battery backup or AC only	Options (For battery backup model)	Housing color	Option	Input voltage
WSU: EXIT Sign	R: Red color, single face	Blank: Battery backup.	Blank: Manual testing, no remote capability.	WH: White	U: Extra one more exit panel for single face and double face universal.	1: 120/277V
		AC: AC input only	CT: Self-testing / Self-diagnostics			
	G: Green color, single face	Blank: Dual AC input. AC/AC circuit	CL: Cold weather optional.	BK: Black		
			ZD: Wireless Reporting LynxEM™ Control			

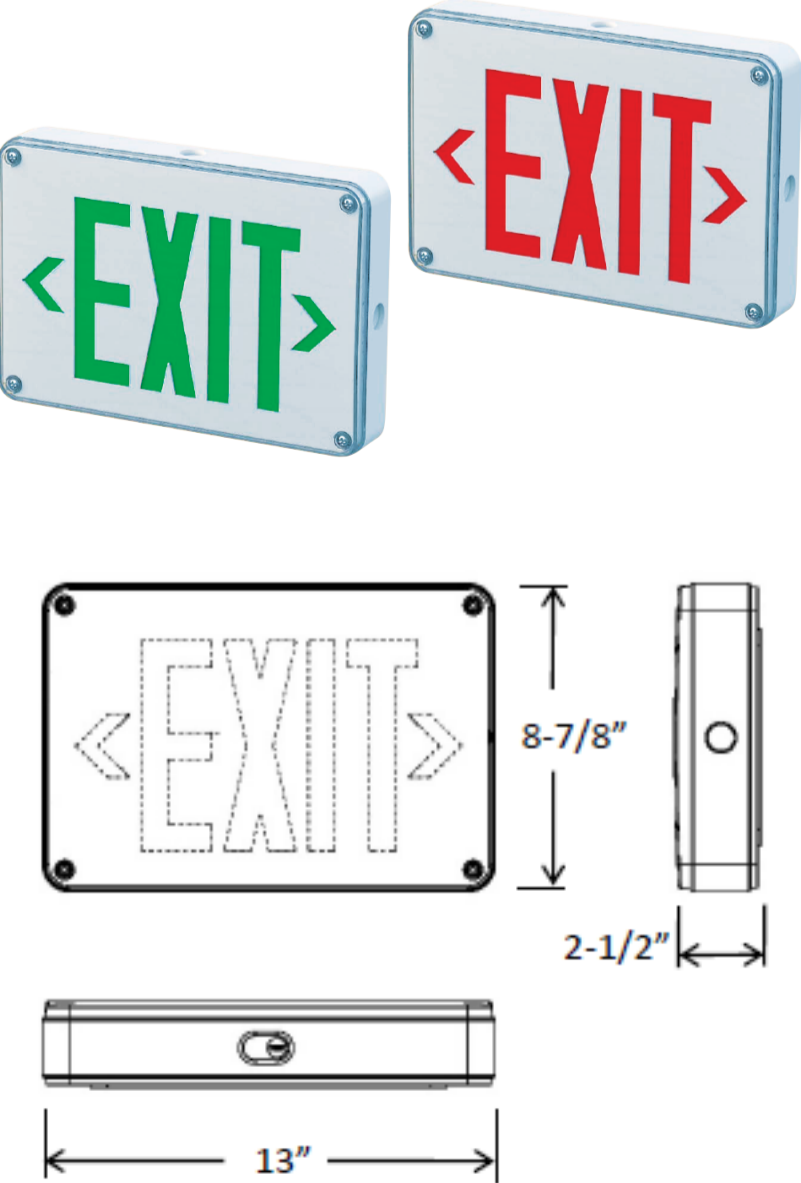

GATEWAYS



EGW – Z004 – M

PRODUCT SPECIFICATIONS

- 5VDC provided with wall plug adaptor.
- Master gateway can handle maximum of 24 slave gateways.
- Maximum capacity: 100 end-node devices.
- Manual on-demand EM tests by APP.
- Schedule Auto EM tests configuration through APP.

- Central test report, history and other maintenance records.
- E-mail test notification and report sending. (option- require cloud access)
- Remote web interface to browse test history and real-time data. (option- require cloud access)

Compatibility	Input	Operating Environment	Radio properties	I/O Port	Dimensions	Warranty
Proprietary	5VDC / 500mA	-20 - + 65°C	2.4GHz Wifi &* Zigbee +19.5dBm transmit	2 x 10/100 Mbps Ethernet, 1xUSB 3.0	200 x 120 x 30 (LxWxH)	5 Years

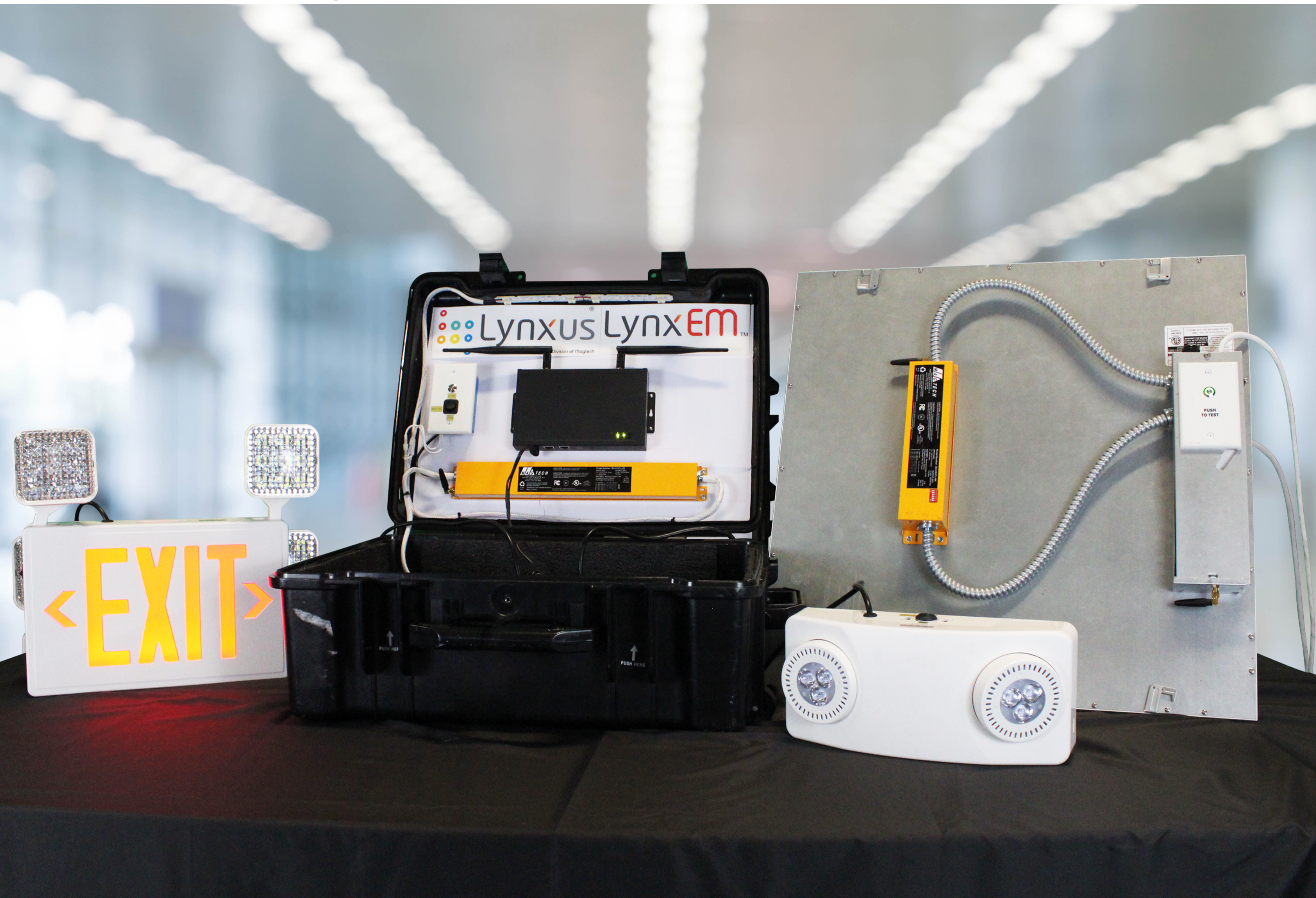

Authorized Distributors



Authorized Representatives



Lynxus[®] Technologies, a division of Magtech Industries Corporation

5625 Arville St # A Las Vegas, NV 89118

(702) 364-9998

www.lynxus.com · www.magtechind.com